



Wireless Data Transmission Module G-BOX

Operating manual

Catalog

1. INTRODUCTION	3
1-1. SUMMARIZE.....	3
1-2. COMPATIBILITY	3
1-3. PERFORMANCE CHARACTERISTIC.....	3
1-4. APPLIED FUNCTION.....	3
1-5. APPLICATION FIELD.....	4
2. PERFORMANCE AND PARAMETER.....	5
2-1. PORT ARRANGEMENT	5
2-2. RS-232 PORT	5
2-3. RS-485 PORT	6
2-4. OUTLINE DIMENSION AND INSTALLATION.....	6
2-5. SWITCH.....	7
2-6. LED INDICATOR LIGHT	7
2-7. PRODUCT CHARACTERISTIC PARAMETER.....	7
2-8. NETWORK COMMUNICATION PROJECT	8
3. OPERATING STEP.....	10
3-1. INITIAL CONFIGURATION.....	10
3-1-1 PREPARATION	10
3-1-2 UNKNOWN STATE.....	10
3-1-3. KNOWN STATE.....	18
3-2. WORKING STATE.....	19
3-2-1. PERMANENT ONLINE.....	19
3-2-2. DORMANCY	19
4. MESSAGE FUNCTION.....	20
4-1. PLC => G-BOX => MOBILE (MESSAGE ALARMING FUNCTION).....	20
4-2. MOBILE => GBOX => PLC (CONTROL FUNCTION).....	23
5. THE CONNECTION BETWEEN G-BOX AND SCADA	25
6. APPLICATIONS	28
6-1. EXAMPLE 1	28
6-2. EXAMPLE 2.....	29
7. Q&A	30

1. Introduction

1-1. Summarize

As a wireless data transmission module, G-box adopts MODBUS-TCP protocol. It is applied in automatic system with XINJE XC series PLC and other products to implement the wireless connection between automatic system and GPRS network or GSM network. Based on this module, we can do remote programming and diagnoses to the PLC, achieve program upload and download through the upper computer software XCP pro configuration of XC series PLC. The mobile user can use message service to control the PLC. So G-BOX is suitable for the cases such as remote monitor of the distributed system.

1-2. Compatibility

The wireless data transmit communication system includes upper computer configuration software XCPPro of XC series PLC (3.0i and above editions available), G-BOX, SIM card containing GPRS service, the PLC which supports MODBUS-TCP protocol.

1-3. Performance characteristic

G-BOX has below characteristics:

- Open and transparent data transmission
- The data transmission terminal integrates with TCP/IP protocol stack, supports TCP, UDP, DNS, PPP, etc.
- Standard industry port: RS-232 or RS-485
- Supporting persistent online mode, offline re-dial and heartbeat function
- Supporting sending and receiving of message data
- Supporting local configuration
- Supporting GPRS and GSM

1-4. Applied function

The applied function of G-BOX in the whole network is shown as below:

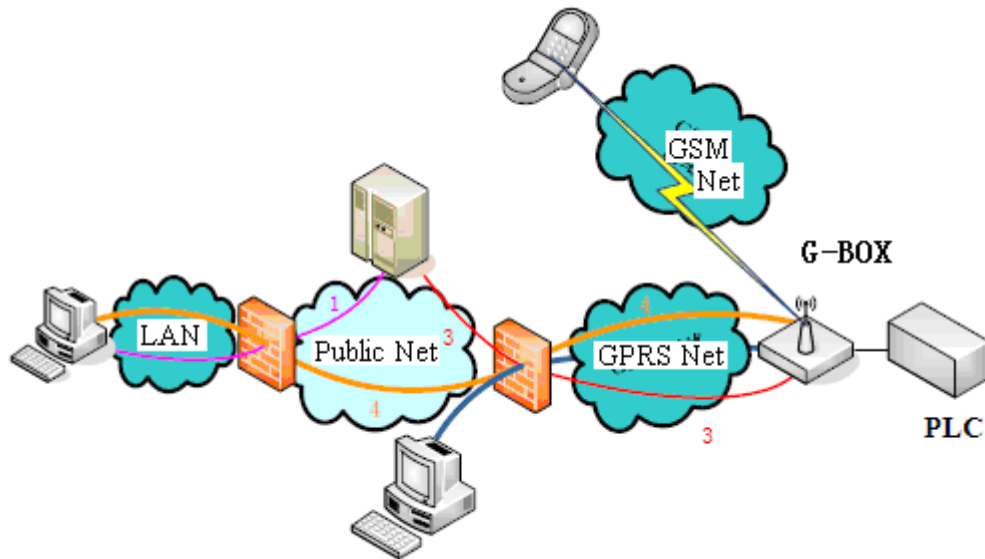

The automatic system based on G-BOX has below functions:

- **Wireless upload and download PLC program and real time monitor**

It seems to be difficult to remote monitor or modify PLC program in remote control system. After equipping with G-BOX, maintenance workers can monitor the PLC even if the control station is far from the local place. It also can realize the program wireless uploading and downloading.

- **Message communicate with user's mobile**

Although G-BOX has message sending and receiving functions, it can't achieve optimal effect as far as the system control object is concerned. If configure a G-BOX module for PLC, user's mobile can send and receive message with PLC through GSM network and monitor the PLC status anytime. If any problem appears, G-BOX will send fault code message to the user's mobile, then the user send the modify message to the G-BOX, the G-BOX will send the message to the PLC. So user can know the problem and solve it immediately.

1-5. Application field

The whole automatic control system could be applied in below fields:

- Industry control, remote sensing, remote measurement
- Monitor nobody-on-duty machine room and storehouse
- Monitor pipe network
- Collect and monitor oil field and coal mine data
- Fault diagnoses of huge equipment
- Any other situations need wireless data transmission

2. Performance and parameter

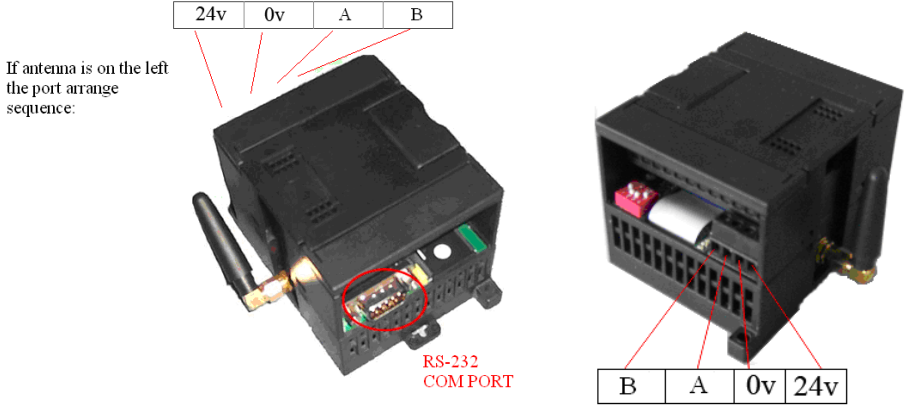

2-1. Port arrangement

- Subject to the antenna on the left, the port arrange sequence is 24V, 0V, A, B
1. The power voltage is DC 24V, allowed range is DC 21.6V~26.4V.
 2. G-BOX serial port is RS-232 or RS-485 (terminal A and B), when use RS-485, port A is "+", port B is "-".

2-2. RS-232 port

RS-232 port has nine pinholes, see below picture:

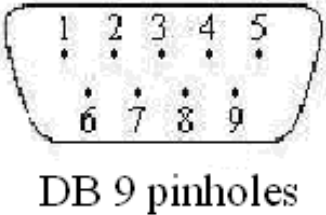

2	RXD
3	TXD
5	GND

PC and G-BOX cable connection figure:

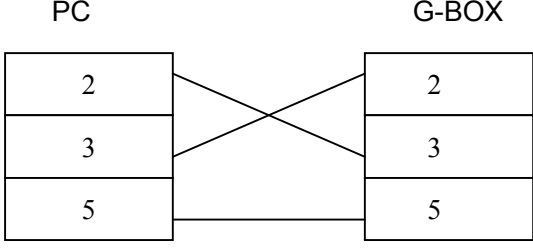

XC series PLC and G-BOX cable connection figure:



G-BOX serial port can only connect with one device (PLC or PC) which uses MODBUS-RTU protocol. GPRS network side uses MODBUS-TCP protocol. G-BOX can communicate with XINJE XC series PLC.

2-3. RS-485 port

When use RS-485 port, connect terminal A, B with PLC terminal A, B.

Attention: RS-232 port and RS-485 port can't be used at the same time.

2-4. Outline dimension and installation

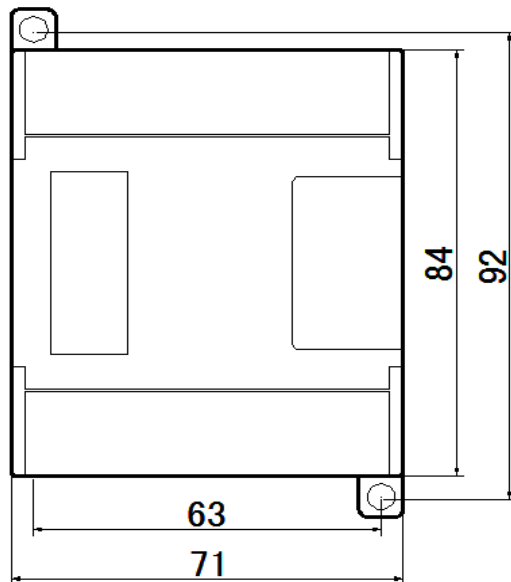

The outline dimension is 71mm×100mm×67mm (width × length × high).

Use M3 screw to fix the module or install on the DIN46277 (width 35mm) track.

Attention:

1. Among installation, avoid metal bits or wire bits dropping into the module
2. Before connecting, please make sure the specs of the module and device are correct
3. Make sure the wire connection is firm. If not, some problem will occur such as data incorrect, short, ect.

4. When installing or connecting with the module, make sure the power is cut off.

2-5. Switch

There are four switches: S1, S2, S3, S4.

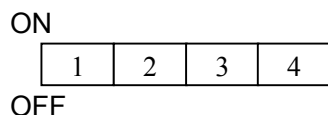

S1	S2	S3	S4	State	Description
Random	OFF	OFF	ON	Parameter setting	Use PC to set G-BOX original parameters
ON	OFF	OFF	OFF	Permanent online	G-BOX has already logged on the server
OFF	OFF	OFF	OFF	Dormancy	G-BOX is dormant, it will log on the server after phone call activation

Note: When setting the parameter, G-BOX receives data from serial port; after exiting parameter setting and return to working status the parameter become effective.

2-6. LED indicator light

LED	Indicate	Function
PWR	Power	On available
COM	Serial port	Glitter available
ONLINE	Connection	On available
GPRS	Mobile phone part works	Glitter once per second: search the network Glitter once per three seconds: connect GSM Quickly glitter: GPRS data transmission On: starting or abnormal

2-7. Product characteristic parameter

Parameter Name	Description
Working frequency band	Single-frequency: 800MHz, Dual-frequency: 900MHz/1800MHz
Receiving sensitivity	< -106dBm
Maximum transmitting power	2W (900MHz) , 1W (1800MHz)
Working temperature	0°C~50°C

Power voltage	DC 24.0V
Average stand-by current	< 7mA (idle mode)
Base current	< 2.5mA
Protocol	GSM/GPRS Phase2/2+
GSC RF antenna connector	50 Ω E GSC
Message service	MO / MT
	Point to point
	Message mode: TEXT / PDU
GPRS data service	GPRS CLASS 10
	TCP/IP protocol: multilinking, ACK answering, high-capacity cache
Dynamic area	62dB
Maximum data transmitting speed	85.6kb/s

2-8. Network communication project

After original setting by the upper computer, G-BOX has below information: Master server IP, port No., device ID, log on name, etc.

There are two cases for activating G-BOX and connect with GPRS network:

Case one:

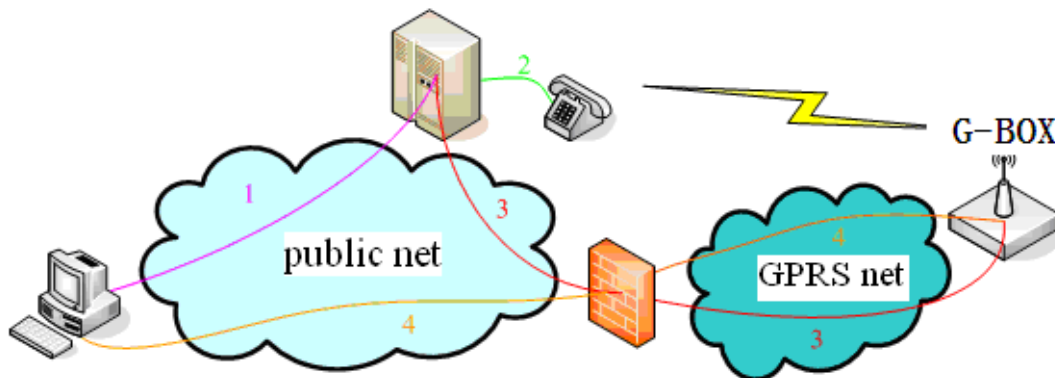

1. The PC on public net (confirmed IP) logs on the server and sends connecting requirement
2. The server calls the phone number of appointed device, hangs up after ringing twice to activate the G-BOX
3. The activated G-BOX logs on the server to obtain the PC information
4. G-BOX connects with the PC

Case two:

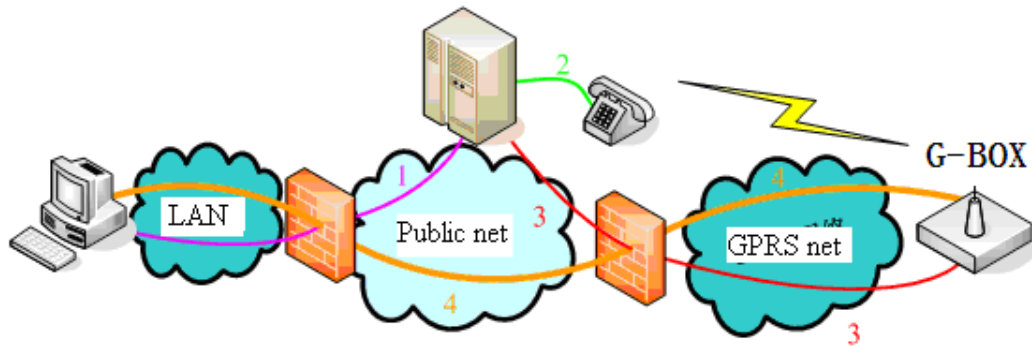

1. The PC in the subnet logs on the server (via NAT service), sends connecting requirement
2. The server calls the phone number of appointed device, hangs up after ringing three times to activate the G-BOX
3. The activated G-BOX logs on the server

The activated G-BOX connects with GPRS net, if it receives end command or doesn't get the data for 3 to 5 minutes, G-BOX will stop the connection with GPRS net.

3. Operating step

The steps are based on hardware version v1.51 and software version XCPpro v3.3.

3-1. Initial configuration

The initial configuration aims to get the corresponding information in XCPpro and G-BOX. G-BOX can be divided into unknown and known state.

3-1-1 Preparation

- **A SIM card**
Choose corresponding services in terms of different control requests
 1. Need remote program maintenance: open GPRS CMNET service
 2. Need message monitoring: open message service
- **One OP/TP download cable** ——used to configure GBOX
- **One XC download cable** —— used to connect GBOX and PLC
- **One PC connected with Internet and installed XCPpro software**
- **Choose a reliable network (do not need confirmed IP, bandwidth, speed, but credible)**

3-1-2 Unknown state

For first time, user need connect the G-BOX with PC to read its parameters and record in XCPpro software. User also can modify the G-BOX parameters and save TCP/IP network setting with the file.

Setting step:

1. Hardware connection and setting

- (1) Set OFF switch 1,2,3, set ON switch 4:

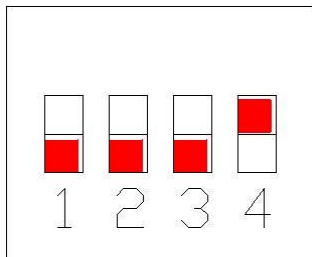

- (2) Connect G-BOX and PC via serial port
- (3) Make sure SIM card inside and GPRS service opened, power on.
Attention: the message remained in SIM card will be cleared

2. Software parameters setting

A. Open software XCPpro, click option/software serial port config. Default value: 19200BPS, even. You can select the serial port. Below window means the connection is successful.

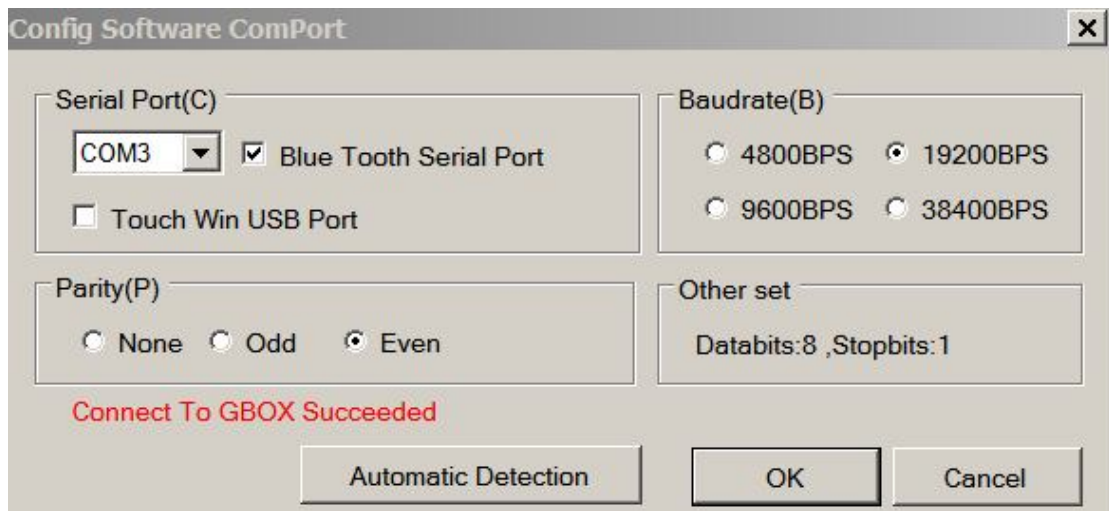

B. Click option/comm mode settings”.

C. Click “+” to set the communication mode

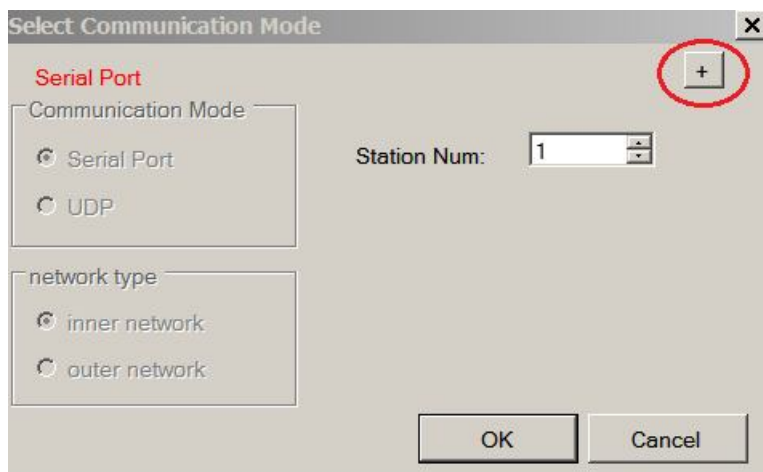

D. Click “Add GBOX”, pop up “Edit GBOX device” window.

Click “Read From GBOX”, the parameters will be shown as upper:

(1) Communication tab

i. Login in

Name: can be set by user. When known the G-BOX communication parameters, only the G-BOX name matches to the project configuration information, G-BOX will connect to the GPRS.

Psw: G-BOX out of factory ID, read only, can be input, but cannot be written into G-BOX.

ii. Remote login in

Server IP: XINJE default server address is 61.160.67.86

Port: 502, cannot be changed unless user build his own server

Server 2 Name: similar to server IP, cannot be changed

iii. Serial Port

Default value, cannot be changed

iv. Station

Connect to target station in GPRS communication. When the station list is blank, only communicate with station 1; when there are many station numbers select the target station in GPRS communication.

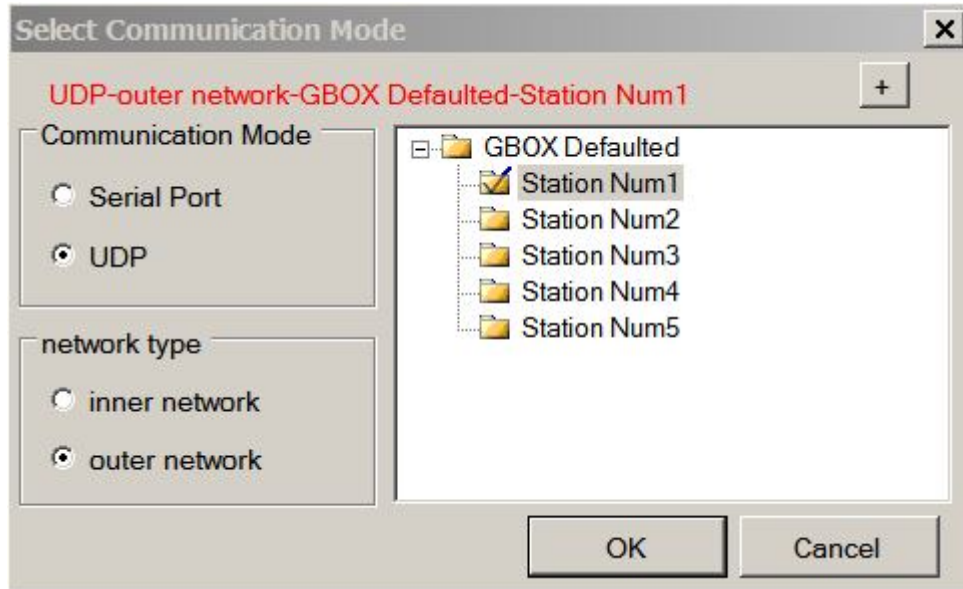

(2) Flag coil tab

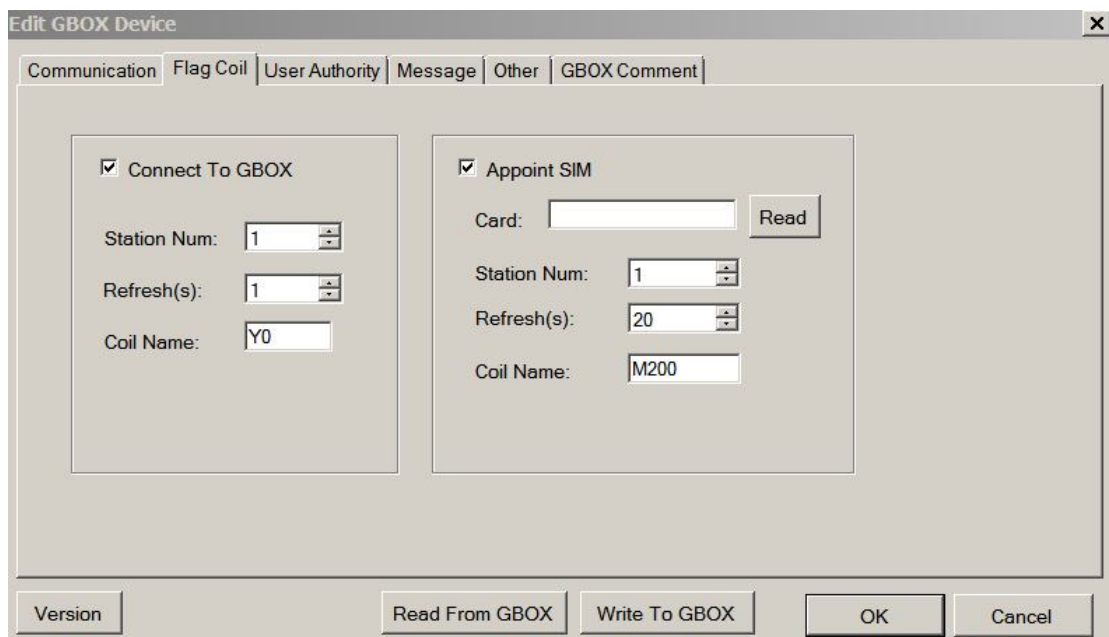

Glossary:

Refresh (s): G-BOX refresh time of connecting to PLC flag coil

Coil name: flag coil address

- Connect to G-BOX
 - i. Station: the G-BOX station number
 - ii. Refresh: change the refresh time by up and down button
 - iii. Coil name: the flag coil address

- Appoint SIM

You can set ON the target coil when G-BOX and appointed SIM card is correspondence.

- i. Card: binding SIM card number
- ii. Refresh: change the refresh time by up/down button
- iii. Coil name: flag coil address

Notes:

- 1. Refresh time has 1% deviation.
- 2. The flag coil will be effective when repower on the G-BOX. The effective time is about 20 to 50 seconds, which depend on SIM card hardware.
- 3. Refresh time will be long when sending/receiving message, uploading/downloading program and monitoring.

The connection between G-BOX and PLC is influenced by time (refresh time and power-on delay). To decrease the error caused by these reasons, we can take below methods:

Suppose G-BOX refresh time of connecting PLC flag coil is 5s.

- Set a 30s timer after PLC power on (the best is 50s, consider PLC power on time).
- PLC uses the flag coil pulse to increase the data register such as D0.
- Set OFF the flag coil, set 15s timer, check the value of D0:
 If D0 value has changed, PLC has connected to G-BOX, clear D0.
 If D0 value has not changed, PLC has not connected to G-BOX, run special operation such as shut down the PLC.

Example: refresh time is 10s, flag coil is M100

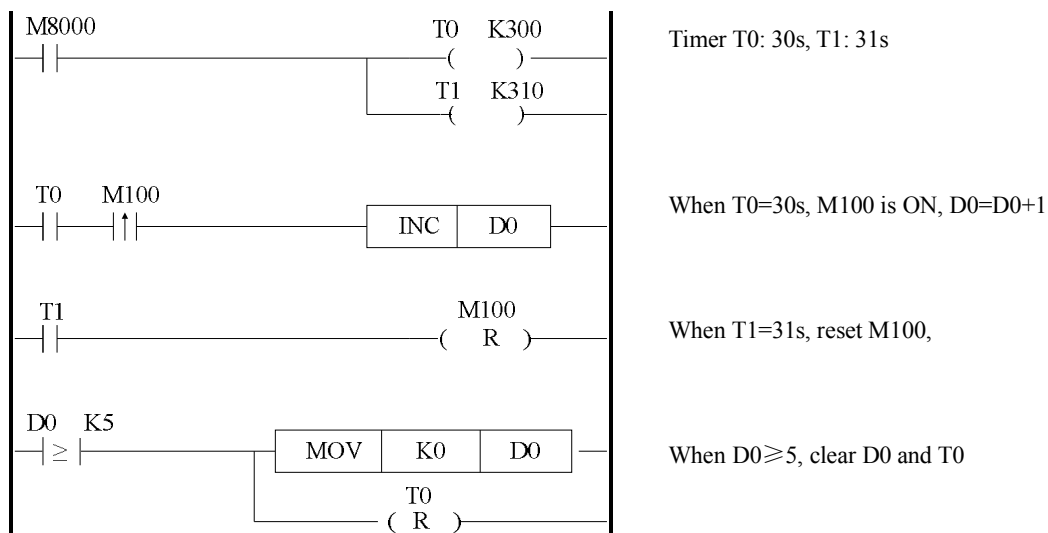

(3) User authority tab

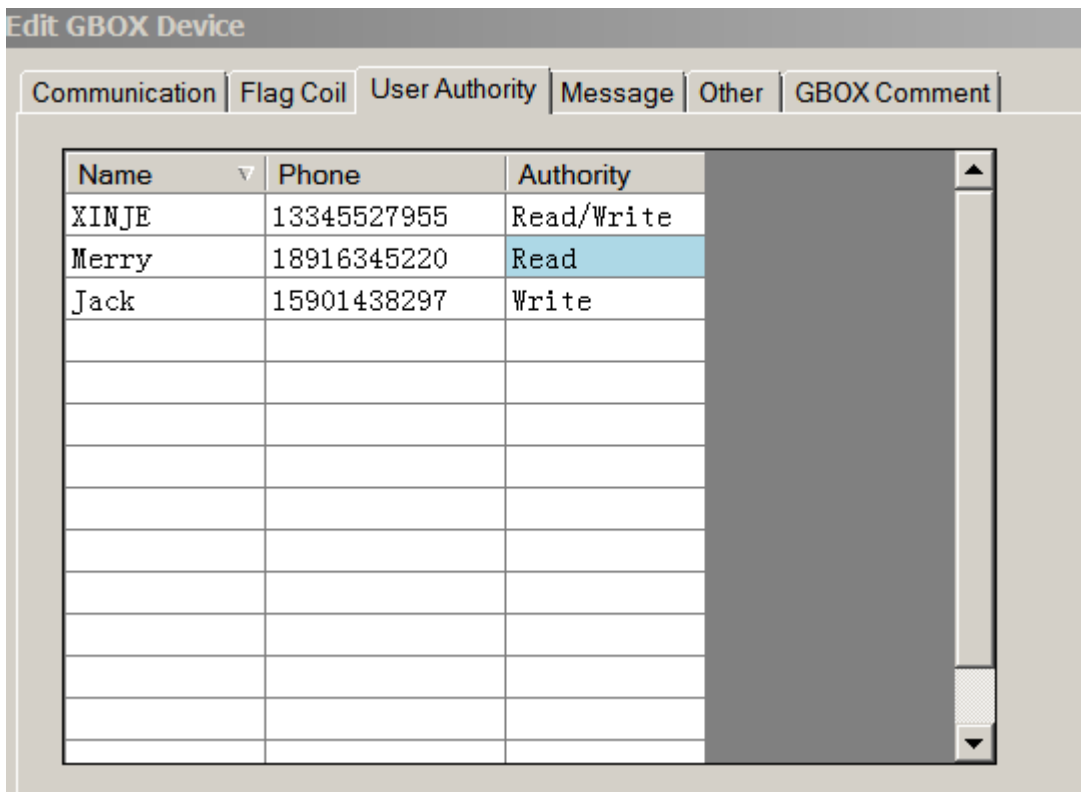

- i. Name: defined by user
- ii. Phone: mobile number which has the authority. When the list is blank, all the users have authority; when fill in the mobile number, only these numbers have authority
- iii. Authority: select the authority by the up/down button

(4) Message tab

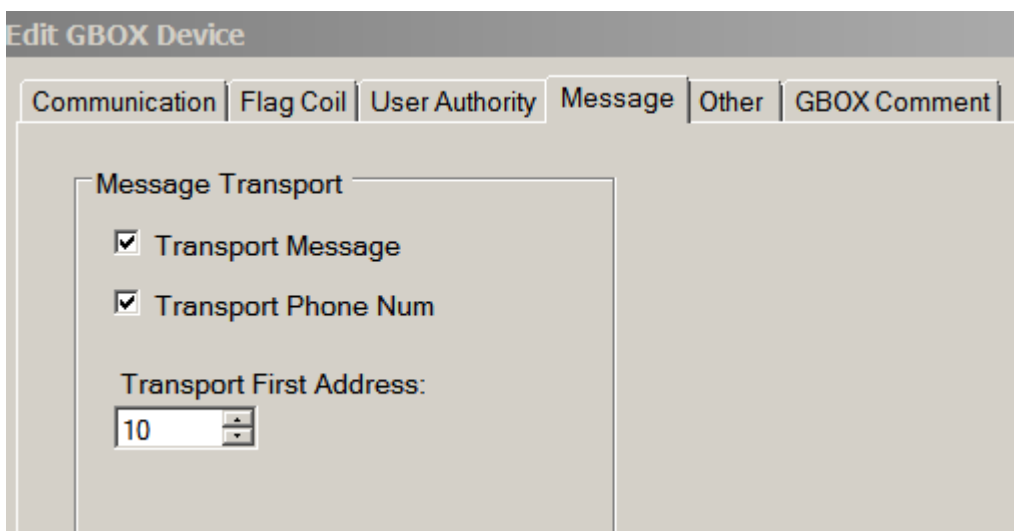

This function is used to save the message sent from mobile to G-BOX.

- i. Transport message: ignore the message read/write protocol; store the message in PLC register D.
- ii. Transport phone num: store the mobile number in PLC register D.
- iii. Transport first address: the first address to store the up contents.

iv. The contents will be stored in below format:

Sequence	Explanation
Register quantity of mobile numbers	0: no number
Register quantity of message	
Mobile numbers	No content if not store numbers
Message contents	

Example1: If select transport message and phone num, transport first address is D10, mobile number: 13612345678, message contents: "ABC".

Display the data in XINJE HMI:

Register	Data type	Data length	Data contents	Explanation
D10	WORD	1	6	Mobile number 13612345678 has 11 numbers, occupy 6 registers
D11	WORD	1	2	"ABC" has 3 words, occupy 2 registers
D12~D17	WORD	6	13612345678	Display 13612345678
D18	WORD	2	AB	Display "AB"
D19	WORD	1	C	Display "C"

Example2: mobile number 13612345678 send message "W Y0 1" to the G-BOX, the transport first address is D10.

Data address	D10	D11	D12	D13	D14	D15	D16	D17	D18	D19	D20
Data type	decimal	decimal	ASCII	ASCII	ASCII	ASCII	ASCII	ASCII	ASCII	ASCII	ASCII
Data contents	6	3	31	16	32	54	76	8	W	0Y	1

(5) Other tab

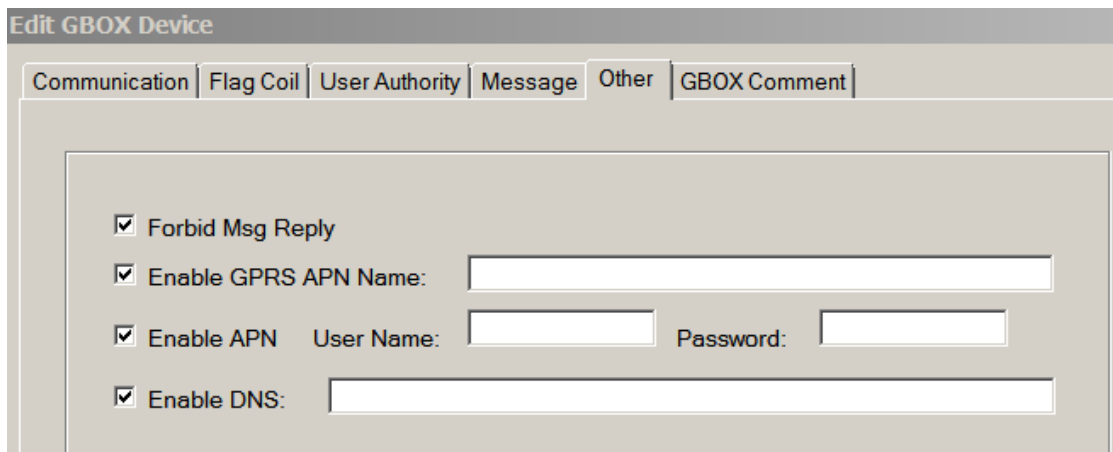

- i. Forbid Msg reply: when user uses message protocol, G-BOX will not reply message "OK" in order to save cost.
- ii. Enable GPRS APN name: mobile service operator name
- iii. Enable APN user name password: if user builds his own server, it needs to input name and password which likes log in wireless router.

- iv. Enable DNS: for dynamic IP, no need to configure it.

(6) GBOX comment tab

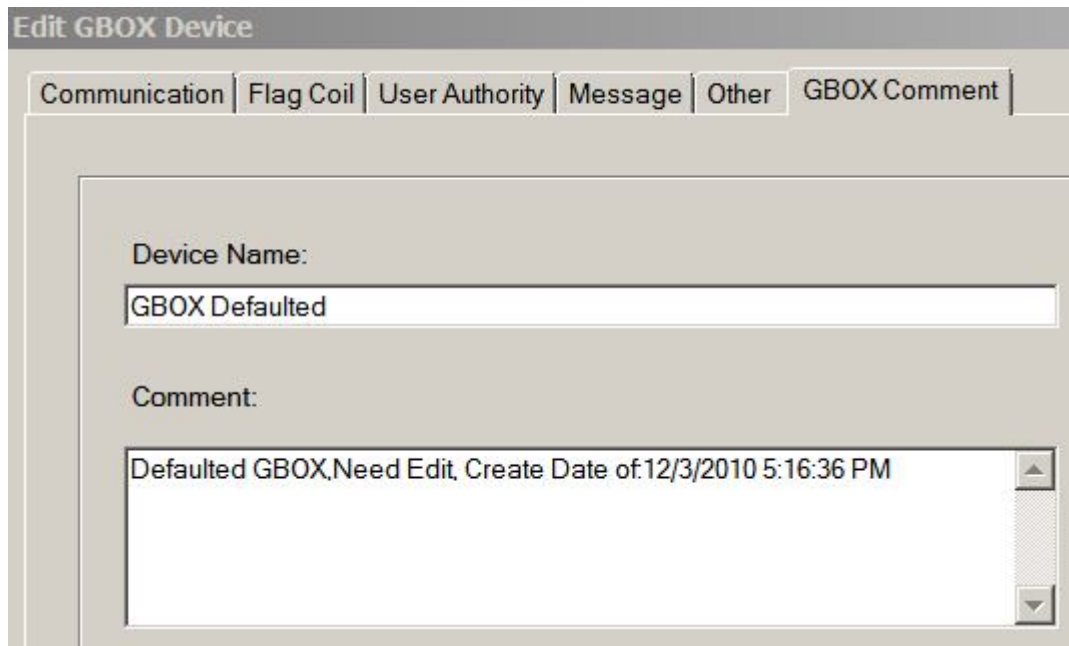

- i. Device name: define the name to differ from others.
- ii. Comment: defined by users.

After configuring all the parameters, click “write to GBOX ---OK”. The G-BOX will be in the device list.

Name	IP	Mask	DNS	Port	Comment
1 GBOX Defaulted	-	-	-	-	Defaulted GBOX...	

E. Close the window, select “UDP, outer network, station Num1”. Then click OK to finish the configuration.

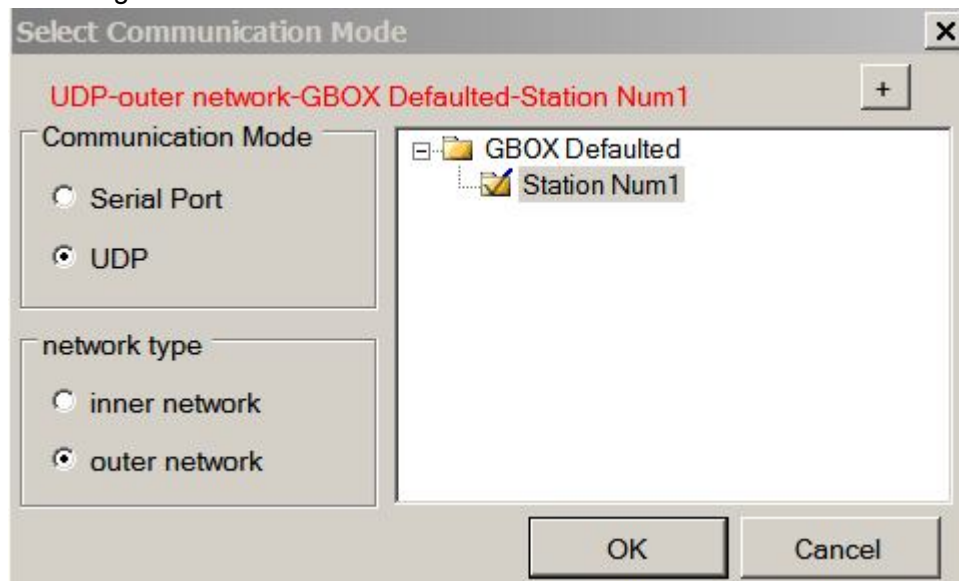

When there are many G-BOX in the device list, please select the object which you need.

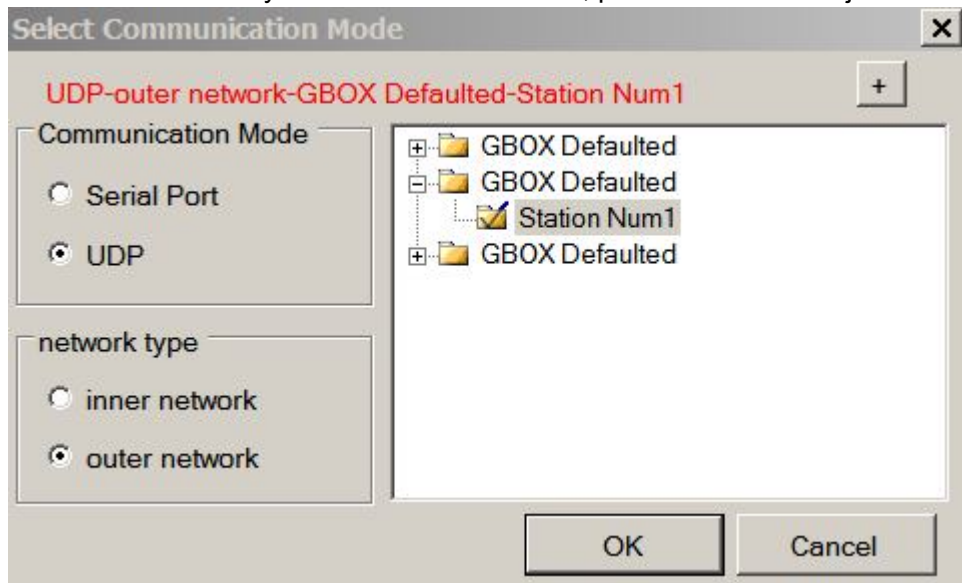

Note: Please restart the G-BOX to make the configuration effective.

3-1-3. Known state

If user knows the information in the G-BOX, it is not necessary to connect the G-BOX with PC. Open the XCPpro software then click “option/comm Mode setting”. Operating steps refer to section 3-1-1. The difference is the “Edit GBOX Device” part. The parameters in “Login in” and “Remote Login in” should be consisting with the parameters in G-BOX. Other steps are the same as 3-1-1.

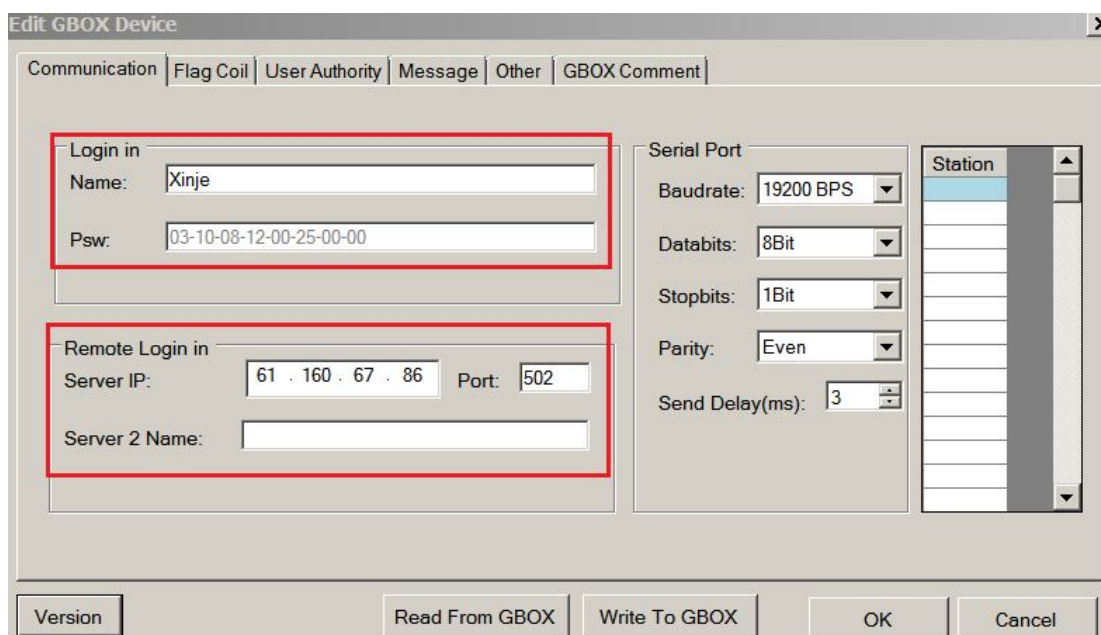

3-2. Working state

After original configuration, G-BOX enters working state. Please connect G-BOX with PLC.

There are two working states: permanent online and dormancy.

3-2-1. Permanent online

Setting:

1. Set ON switch 1, set OFF switch 2, 3, 4.
2. Make sure SIM card inside, GPRS service opened, power on.
3. LED signal "ONLINE" on, G-BOX has log in the server. XCPpro software has connected with GPRS network.

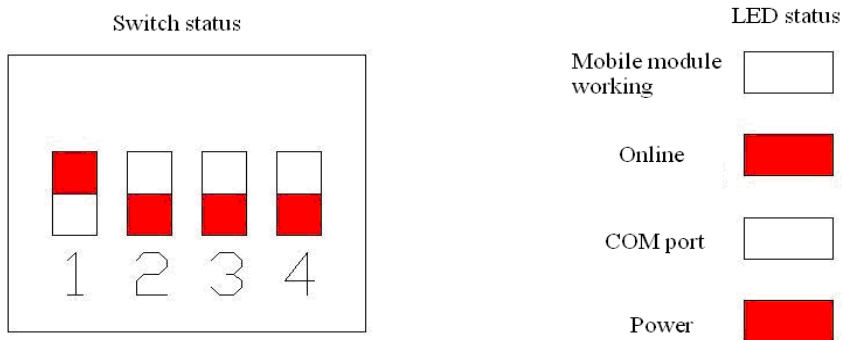

3-2-2. Dormancy

This mode can save cost of non-use state. User can activate the G-BOX by making a phone call, and then G-BOX will re-log in the server and connect XCPpro with GPRS network.

Setting:

1. Set OFF switch 1,2,3,4
2. Make sure SIM card inside, GPRS service opened, power on.
3. Call the SIM card number of G-BOX until it refuse to answer.
4. The following steps are the same as "permanent online state". If no operation for 5 minutes, G-BOX will dormant. It need to activate the G-BOX by phone call when use next time.

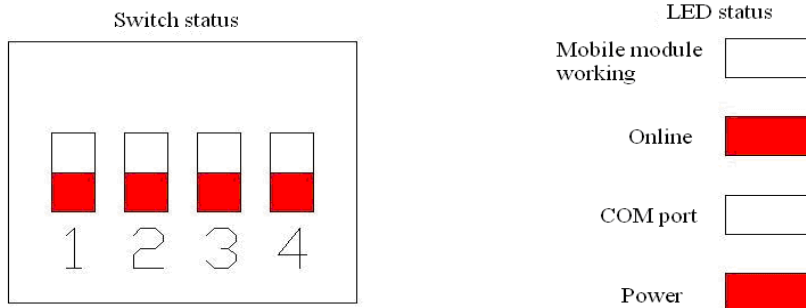

Under up two states, XCPpro tries to connect with G-BOX by P2P (see below figure). If the connection is failure, the server will forward which will affect the connection speed. If connection is successful, user can download/upload and monitor the program in XCPpro software. Generally, monitoring will delay for 3s.

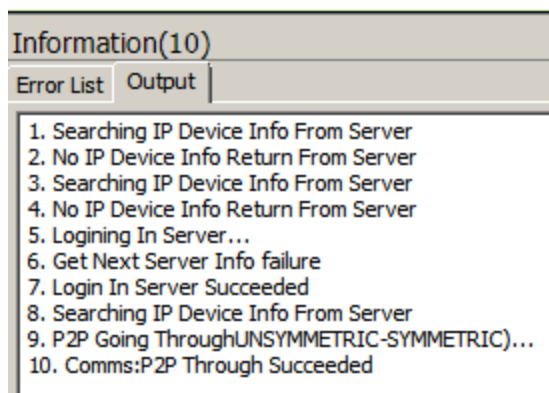

4. Message Function

When G-BOX switch 4 is set on, it is under message mode. Message function is available even the G-BOX is not activated. There are some notes for user:

1. During the first 50 seconds after power on, the G-BOX is initializing, it will not give correct answer for any requests.
2. If the data is transmitting in GPRS network, the communication from PLC to mobile will be affected (message alarming function), but the communication from mobile to PLC will not be affected.

There are two modes in terms of data transmitting direction:

4-1. PLC => G-BOX => Mobile (Message alarming function)

Under this mode, PLC is master, G-BOX is slave, the slave station number is FF (HEX). XCPpro v3.0i and higher version, PLC hardware v3.0i and higher version support G-BOX. There are two modes to realize message alarming function:

1. Toolbar shortcut:

Click "MSG Config" to configure the message.

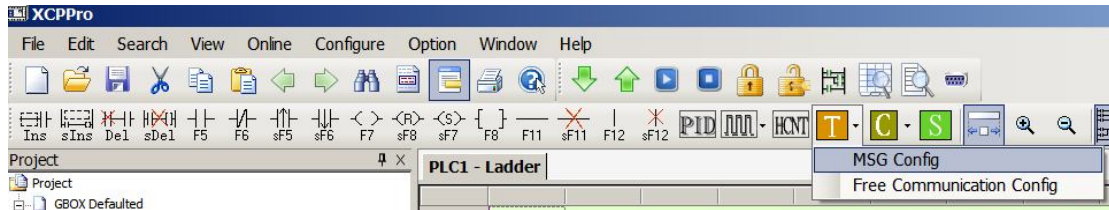

MSG Instruction Config setting

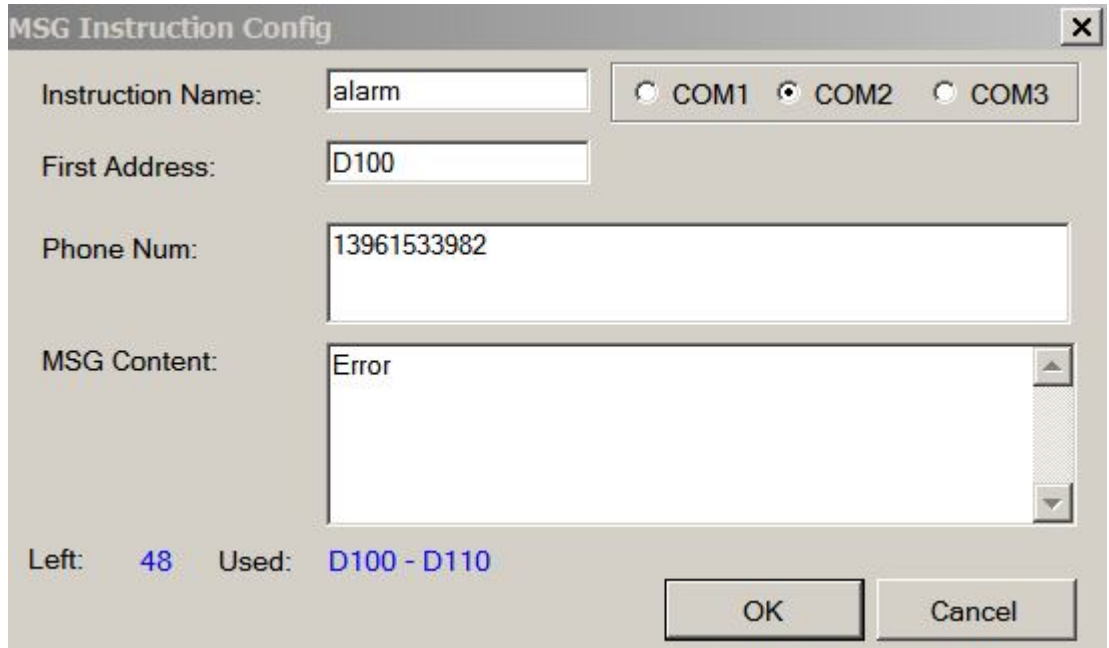

Click OK to build below ladder chart.

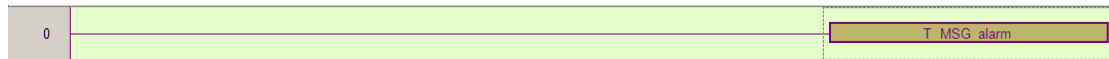

2. PLC program instruction "MRGW":
G-BOX slave station No. is FF (HEX), head address is 50000 (decimal), 50000 can be instead by -15536 (decimal) or C350 (HEX).

Sending format: Station No. + Function code + Head address + Register quantities + Byte quantities + Register value + CRC check code

Answering format: Station No. + Function code + Register quantities + CRC check code

Sending Format		Answering Format	
Name	HEX	Name	HEX
Station No.	FF	Station No.	FF
Function code	10	Function code	10
High byte of head address	C3	High byte of head address	C3
Low byte of head address	50	Low byte of head address	50

High byte of register quantities	00	High byte of register quantities	00
Low byte of register quantities	01—78	Low byte of register quantities	01—78
Byte quantities	Register quantitiesN×2	Low byte of CRC check code
High byte of register value	00—FF	High byte of CRC check code
Low byte of register value	00—FF		
High byte of register value	00—FF		
Low byte of register value	00—FF		
.....		
.....		
Low byte of CRC check code		
High byte of CRC check code		

The register content is: register quantity of telephone number buffer + zeros + message contents.

In order to compatible with the data display of TouchWin series HMI, accordance with the above order, high and low byte in each register are reversed, telephone number list and message contents are ASCII code.

The instruction should not be greater than 128 bytes (message + register quantity of telephone number should not be larger than 64).

For example:

Send ABCD to mobile number 13012345678, the data in communication buffer are:

0x00 0x06 0x33 0x31 0x31 0x30 0x33 0x32 0x35 0x34
0x37 0x36 0x00 0x38 0x42 0x41 0x44 0x43

Occupy 9 registers.

If error occurs, the answering format is:

Error code	0x90
Other code	01 or 02 or 03 or 04

The following contents will explain the message sending process based on XC series PLC instructions. D0 is local head address, mobile number is 13612345678, and message contents are ABCDEFGH.

(1) Ladder chart

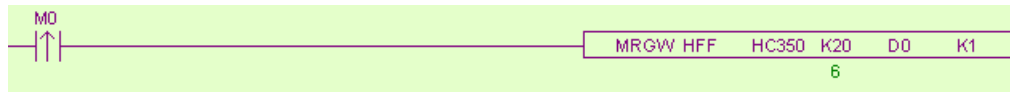

(2) D0 is head address, below is address explanation:

Data address	D0	D1	D2	D3	D4	D5	D6	D7	D8	D9	D10
Data type	Decimal	ASCII	ASCII	ASCII	ASCII	ASCII	ASCII	ASCII	ASCII	ASCII	ASCII
Data content	6	31	16	32	54	76	8	AB	CD	EF	GH

4-2. Mobile => GBOX => PLC (Control Function)

Under this mode, G-BOX is master, PLC is slave, the slave station No. is 1.

The message instruction format:

Instruction	Operating object		Data	
Coil read & write	Bit	M	M0~M7999	0 or 1
			M8000~M8511	
		X	X0~X511	
		Y	Y0~Y511	
		S	S0~S1023	
		T	T0~T618	
		C	C0~C634	
Register read & write	Word	D	D0~D7999	K-32,768~K32,767 H0~HFFFF
			D8000~D8511	
		TD	TD0~TD618	
		CD	CD0~CD634	
		FD	FD0~FD5000	
			FD8000~FD8511	
	Double words	DD	D0~D7998	K-2,147,483,648~K2,147,483,647 H0-HFFFFFFF
			D8000~D8510	
		DTD	TD0~TD616	
		DCD	CD0~CD632	
		DFD	FD0~FD4998	
FD8000~FD8510				

Note:

- All the letters in the message should be capital.

2. Leave a space among instruction, register and operand, the message should not over 99 letters.
3. If sending a character string message, use English quotation mark " .

String read & write command format:

Read command	R	D (D0~D7999)	Sn (n is the string length in decimal)
Write command	W	D (D0~D7999)	String contents

For example:

Read soft component value

Sending message: R M0

Answering message: M0=0

Sending message: R D5

Answering message: D5=K1234

Sending message: R DD0

Answering message: DD0=K654321

Read character

Sending message: R D0 S20

Answering message: Thinget Made (S means the String length in decimal)

Write soft component value

Sending message: W M0 1

// Set ON M0

Sending message: W Y23 0

// Set OFF Y23

Sending message: W Y35 1

// Set ON Y35

Sending message: W D5 K1234

// write 1234 to register D5

Sending message: W DD0 H654321 // write 654321(HEX) to register D0~D1 (double words)

Write character

Sending message: W D0 "Thinget Made" // write Thinget Made to register group D0~Dn

The answering message of write command:

OK

// communication succeed

MODBUS ERROR

// MODBUS communication error

UNKNOWN ERROR

// communication error between G-BOX and PLC

TIMEOUT

// communication timeout between G-BOX and

PLC

If no answering message, the communication between G-BOX and PLC is failure

5. The connection between G-BOX and SCADA

When G-BOX connects to SCADA, it can monitor and control the devices in remote place. It makes the automation system visualized and operational.

We use the SCADA of XINJE Touchwin software (version $\geq 2.C.6$) to connect with G-BOX.

The steps are as below:

(1) Build a new file

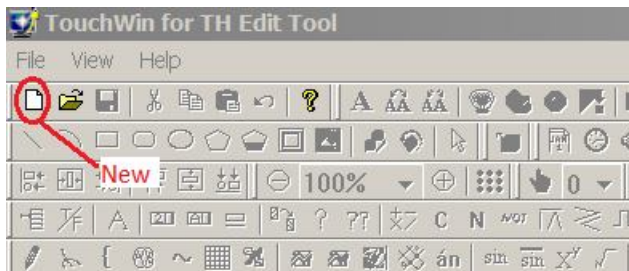

(2) Select PC HMI software/Win800*600 or Win 1024*768 (according to your PC screen size).

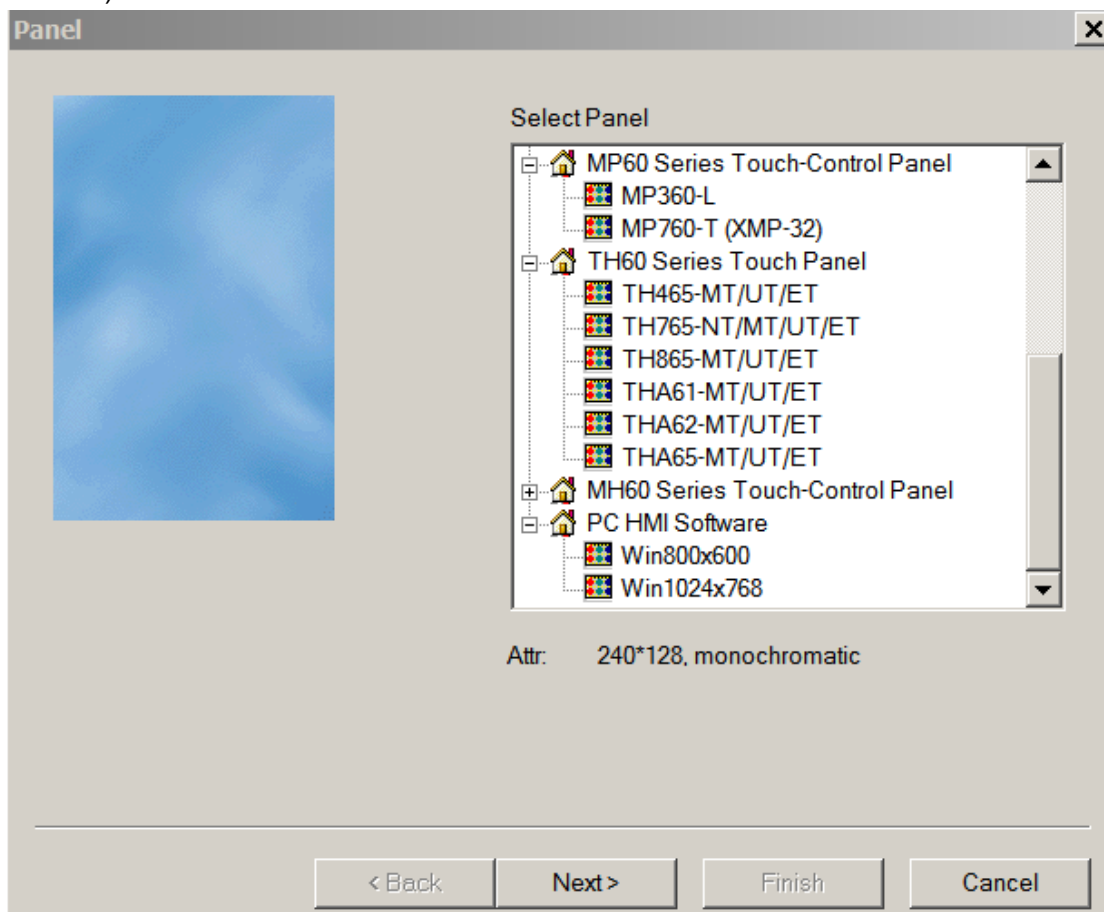

(3) Click "Next", then PLC port device select "Thinget XC series"

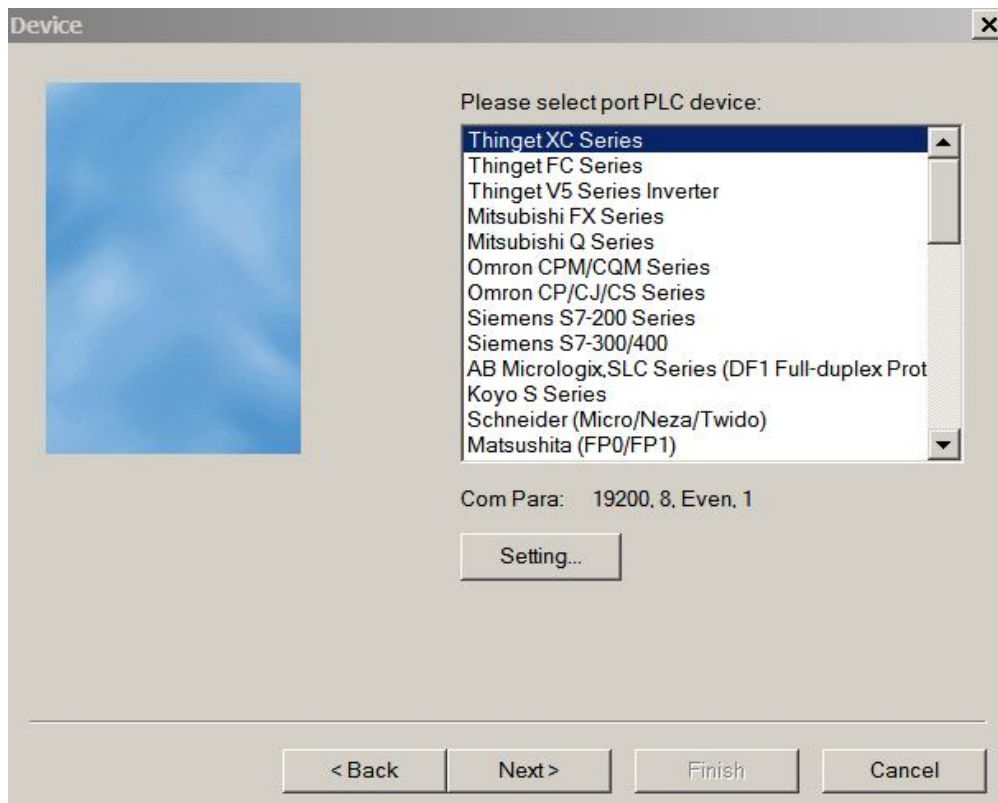

(4) Download port device select "unused download port" then click "Next"

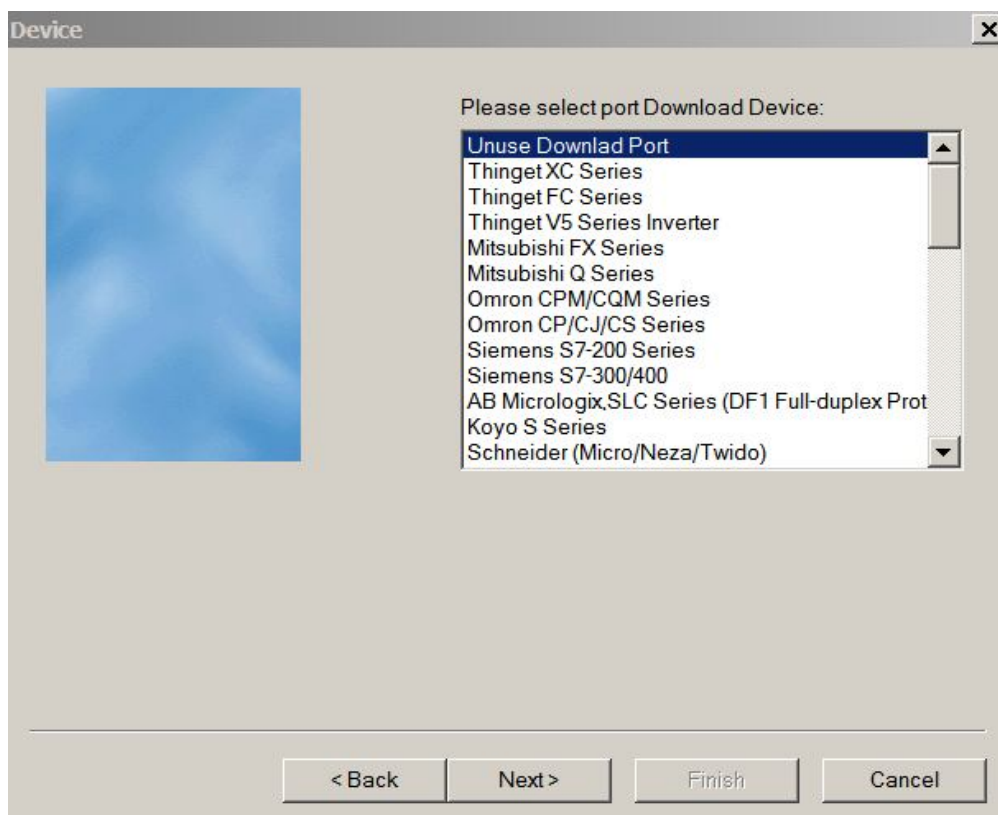

(5) The parameters in below window:

- Name: G-BOX log in name
- User ID: G-BOX log in Psw. Please delete the “-“ when input the Psw. For example: Psw 01-10-02-21-00-01-00-00 will be 0110012100010000.
- Device: select the device in the drop-down list, then click “Add”.
- Server IP and port: G-BOX remote log in server IP and port.

Click “Next” to finish the configuration.

Net Device

Name: thinget

User ID: 0110012100010000

Device: ThingetXC Series

Buttons: Add, Modify, Delete

List: thinget ThingetXC Series

Server IP: 61 . 160 . 67 . 86

Port: 502

Bottom Buttons: < Back, Next >, Finish, Cancel

(6) Make the project in below window:

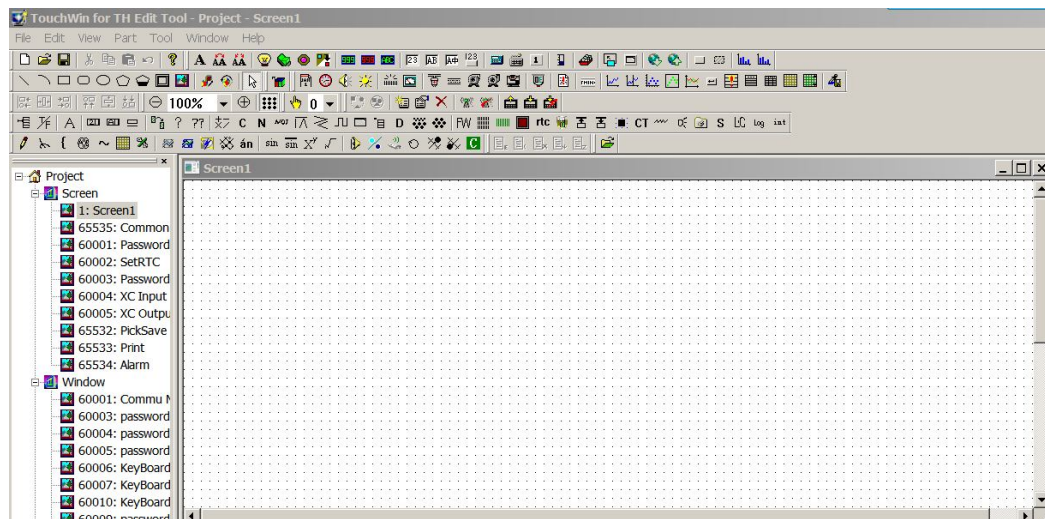

Please note: for all the objects in the project, please change the “PLC port” to network device. For example: the lamp button, change “PLC port” to “thinget XC series”.

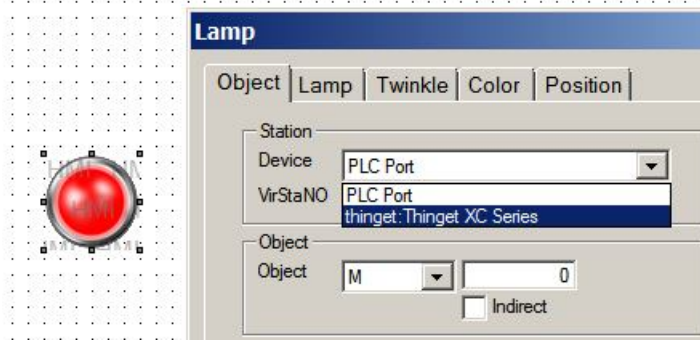

(7) After finishing the editing of project, click online simulation button to monitor the remote device.

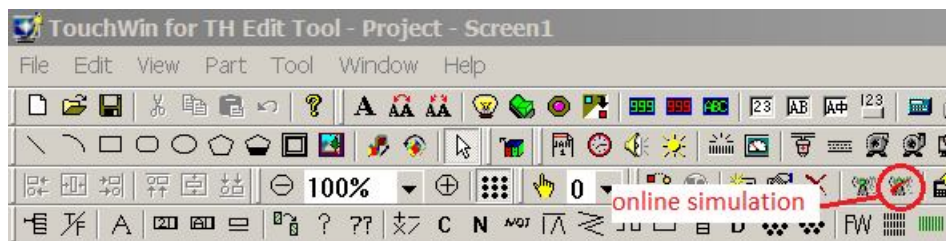

6. Applications

In industry control system, the surrounding condition of control object will influence the results of the whole control system we expected. This brought higher requests to the operator. How to make use of communication technology to optimize the resource configuration and improve efficiency has become a new thinking direction. G-BOX can solve the remote control problem and improve the control system efficiency.

6-1. Example 1

Monitor nobody-on-duty machine room and storehouse, modify the PLC program.

1. For initial using, configure G-BOX parameters in XCPpro, refer to paragraph 3-1. Then record the configure information you have written into G-BOX.
2. There are two work modes: permanent online and dormancy. Choose one kind of mode by setting the switch 1 to 4. Connecting G-BOX with PLC in control system.
3. Engineers can use software XCPpro to download, upload and monitor the program in remote PLC; you also have to know the G-BOX original setting information.

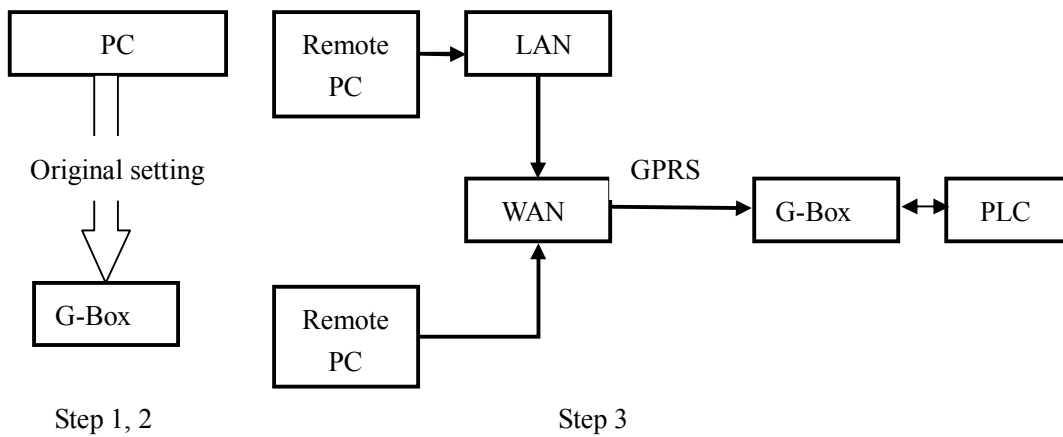

6-2. Example 2

In nobody-on-duty control system, if the system has some problems such as over standard temperature, the PLC will send alarming message to operator via G-BOX.

The steps as below:

1. For initial using, set original parameters of G-BOX, refer to paragraph 3-1.
2. Make sure there is alarming instruction in PLC program. Connect G-BOX with PLC, user can send and receive message by mobile to know the PLC information.

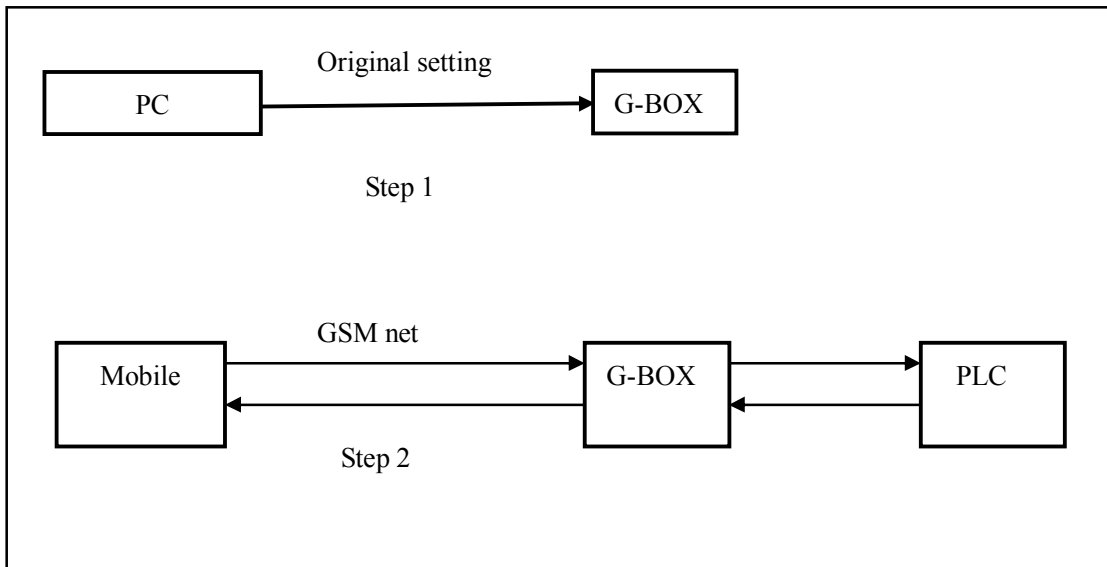

7. Q&A

1. How to ensure the stability of long-time working of G-BOX?
New version has better solution for this problem. The solutions are control the G-BOX power by PLC and ensure G-BOX stability by G-BOX flag coil.
2. When XCPpro software and G-BOX hardware version is inconsistent, show read parameters error.
Write G-BOX parameters with the latest version, and then read again. For “Name”, “server 2 name”, please write in before configuration.
3. Finding errors steps when wireless monitor/download/upload PLC program via G-BOX.
 - (1) Make sure SIM card has opened GPRS
 - (2) The server works fine
 - (3) XCPpro has read the information of G-BOX
 - (4) Make sure the DIP switch of G-BOX are in right position
4. How to communicate PLC with G-BOX via message
 - (1) Make sure SIM card has opened GPRS
 - (2) The DIP switch of G-BOX are in right position
 - (3) In the communication of PLC to G-BOX, the message only supports G-BOX station No.1; please connect the device of MODBUS station No.1.
 - (4) When PLC sends message to mobile via G-BOX, there is no limit on station number. It only requires that the PLC port is consistent with the set one.
 - (5) Please input capital English letters when the G-BOX hardware version is below 1.16.
5. G-BOX offline
There are below reasons for G-BOX offline:
 - (1) G-BOX is in some place that has no signal. Solution: move G-BOX to another place with good signal or change a longer antenna.
 - (2) SIM card is arrears down
 - (3) The server has problem

